



CONTENTS

Shakers

Introduction	88
Shakers	89
Shaker Reference Chart	91
RST Style Shaker	94



**Together
For Success**



Quality

Parts



INTRODUCTION

Black Ace® Shakers

Black Ace® Shakers are made to separate dirt and other materials from products such as potatoes, and other root crops, by lifting and dropping the rod chain, creating a shaking action.

- Made For A Wide Range Of Conditions And Applications
- Heat Treated Steel For Durability And Better Rod Vibration
- High Durability
- Easy Bearing Replacement
- Aggressive To Very Gentle Shaking Action



Quality

Parts

H2P156AY1

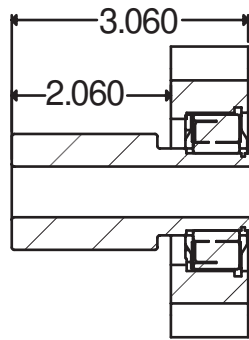

Heat Treated Steel • 1" Wide
Bearing Kit BGAS/W
ASSY DWG AD1

H4P50MAY2

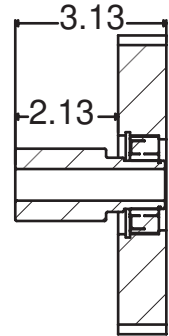
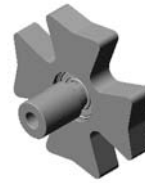

Heat Treated Steel • 1" Wide
Bearing Kit BGAS/W
ASSY DWG AD1

H4P56DAEB2

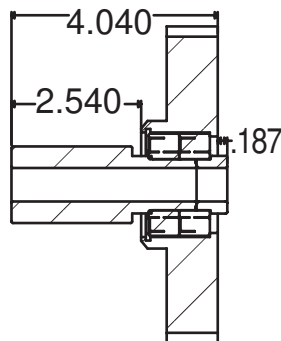

Heat Treated Steel • 1" Wide
Bearing Kit BGAS/U
ASSY DWG AD15

HR21DAEB2

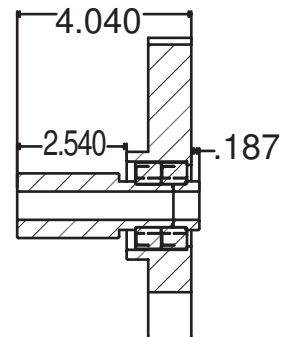

Heat Treated Steel • 1" Wide
Bearing Kit BGAS/U
ASSY DWG AD15

HR21MAY2

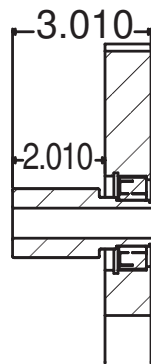

Heat Treated Steel • 1" Wide
Bearing Kit BGAS/W
ASSY DWG AD1

SR21MU

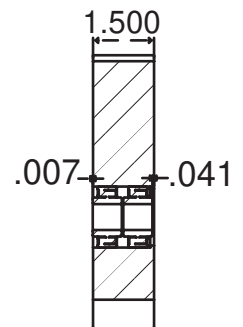

Urethane Shaker
Double Bearing BGBE
1.5" Face • 5/8" Bolt Hole



H3PSGAY1

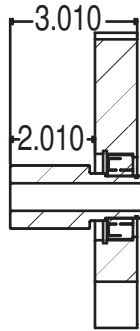
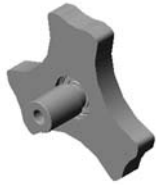

Heat Treated Steel • 1" Wide
Bearing Kit BGAS/W
ASSY DWG AD1

Steel Shakers transmit a type of vibration helping to separate dirt and other debris from product.

Chain Pitch Chart

Millimeter to Inches Conversion Chart

MM	INCH	MM	INCH	MM	INCH
28	1.102	72	2.835	135	5.315
32	1.260	80	3.150	144	5.669
36	1.417	84	3.307	150	5.905
40	1.575	90	3.543	160	6.299
42	1.653	96	3.779	168	6.614
45	1.772	100	3.937	180	7.087
48	1.890	108	4.252	190	7.559
50	1.968	112	4.409	200	7.874
56	2.205	120	4.724	216	8.504
60	2.362	126	4.961	225	8.858
64	2.520	128	5.039		

Conversion based on 25.4 millimeters equal to 1 inch

Use this chart to help determine which style of shaker and size of RST style shaker you may need.



Use the chart below to help determine which is the best shaker for your application.

Shakers							
Shaker Body	#of Points	Pitch	Apprx. Vertical Movement	Action	# of Bearings	Width of Point	Max Height of Lift
H2P156	2	1.56" 40mm	1 3/8"	A	1 BGAS	2.1"	3.13
H3PSGA	3	Up To 2.00" 50mm	1 9/16"	A	1 BGAS	2.1"	3.13
H4P45	4	1.75" 45mm	5/8"	M	1 BGAS	2.3"	2.29
H4P56	4	2.25" 56mm	7/8"	M	1 or 2 BGAS	2.8"	2.90
HR21	3	Up To 2.5" 56mm	1 3/4"	A	1 or 2 BGAS	2.4"	3.58
SR21MU	3	Up To 2.5" 56mm	1 3/4"	A	2 BGBE	2.3"	3.58

A = Aggressive • M = Moderate

Please note the H4P50, H4P56 and HR21 style shakers are available in single or double bearing. For hook chain use the conversion chart for best pitch match. Please refer to page 7 for shaker offset mounting.



The Black Ace® Roller Shakers

Black Ace® Roller Shakers are specifically designed rollers which are positioned so that they lift and drop chain rods causing separation of particles that can pass between the chain rods.

Shown: R27A rollers mounted on a RSSH bracket. Note the wave-like motion as the rods pass over each roller.

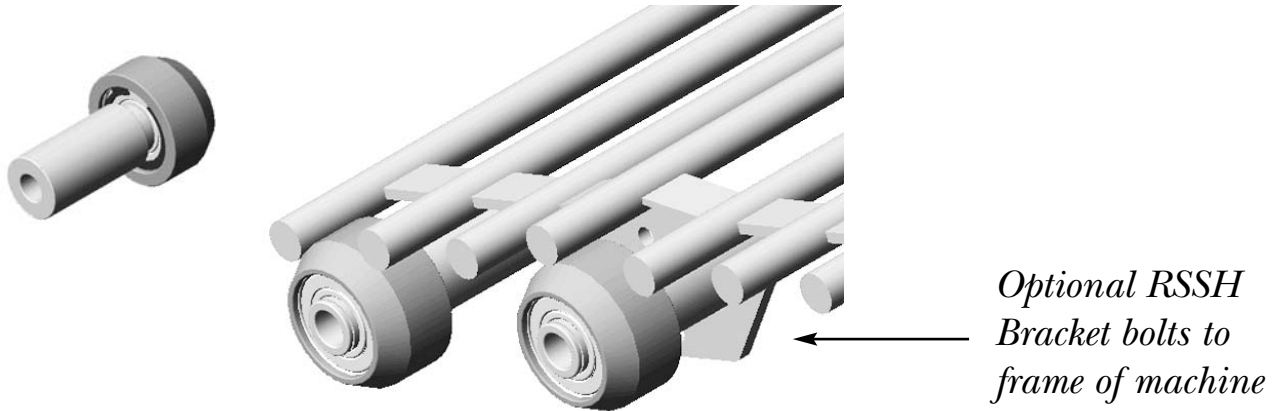

[Note that the belt section of the chain has been removed for clarity.]

By using the R27A Roller Shaker, the motion of the chain is controlled by the pitch of the chain, the weight of the product on the chain and the speed that the chain travels. This action is **extremely gentle**, but **very effective**. This roller has been used very successfully in many contests for bruise free products. It has gained popularity because it requires virtually no skill to operate (unlike hydraulic-style shakers). Since the heat-treated steel roller contacts every rod with minimal lift, it is extremely gentle, leaving very little chance of bruising even the most delicate produce. It actually **vibrates each rod**. To the right is a chart showing the lift of each rod of the different pitched chains with the R27A roller.

Using 7/16" Rod	
Chain Pitch	Vertical Travel
36mm	.17
40mm	.21
45mm	.27
50mm	.35
56mm	.45





Shaker Bracket

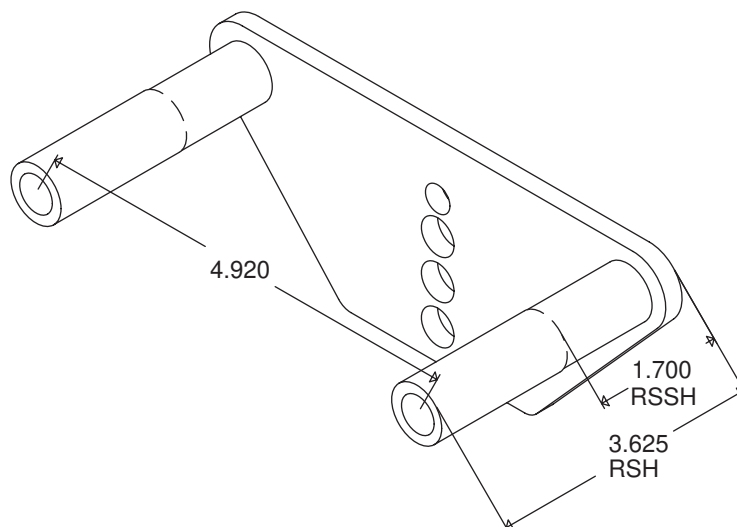

Shown is the RSSH and the RSH bracket which may be used for additional shaking action where additional holes in a frame can't be drilled and where close spacing of rollers may be desired. If you use the RSH-style bracket which is drilled and tapped for a 1/2-13 thread you may put the WA7 friction washer (below) between the RSH and frame to keep it from rotating, or drill an additional hole and bolt the bracket with two bolts.

WA7 Washer

Heat Treated
5/8" Bolt Hole
2" O.D.

Used with P2 stub shafts for
scraper applications

Also used for RSH shaker brackets



To use the R27A Shaker properly, it is important to maintain the top of the roller height so that the chain is pulled across the shaker rollers in a straight line. You may need to drill holes in the frame of your equipment to maintain that height. If replacing 4" rollers, drill 5/8" above and 1 1/4" above for 5" roller holes.

R37AU2

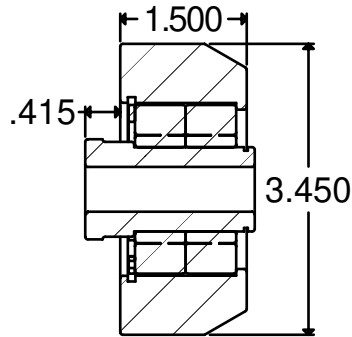

Steel Body
Bearing Kit Use BGAS/U
ASSY DWG AD6

The R37AU2 is a roller used for hydraulic-style shakers that runs under the belt portion of the chain. It has double bearings for high durability.

RST Style Shaker

The RST style shakers are used on override trash chains that use two different roller diameters. As the chain is pulled across the shaker assembly, the larger diameter roller lifts up the rod section of the chain and drops the belt section of the chain onto the small roller of the shaker assembly, resulting in a controlled shaking action.

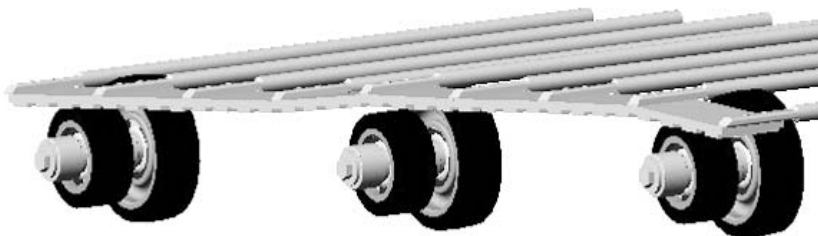

There are three different RST Shaker roller assemblies to choose from. The RST52, RST62 and RST72. Each come with three different large diameter rollers to accommodate the different chain pitches used and the amount of vertical travel you may want.

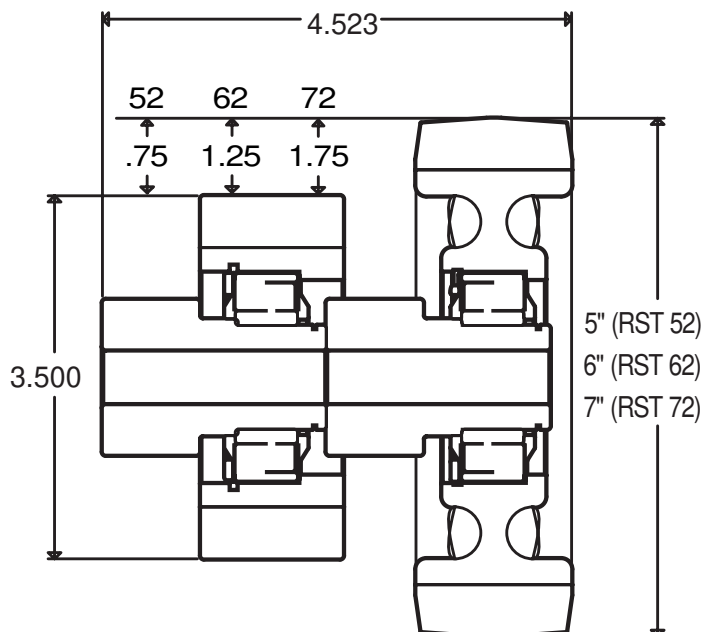

Please note that to get the maximum vertical travel, the pitch of the chain must be large enough so that the belt will contact the 3.5” roller (RSBRRY2) of the roller shaker assembly.

Chain Pitch Chart
Page 90

- ROLLER
- 5" R5RRY2 (RST 52)
- 6" R6RRY2 (RST 62)
- 7" 2973Y2 (RST 72)

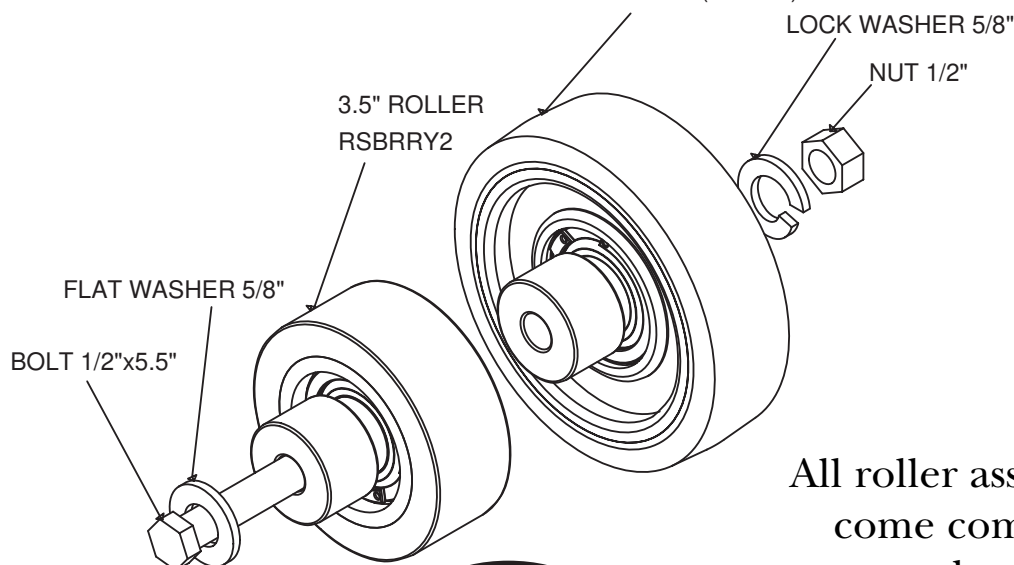

All roller assemblies
come complete
as shown.